

Installation Instructions

Aut-O-Loc 2™ Safety Strap by Progressive

Caution

- ① Use scaffolding or lift when attaching safety belt.
- ② Safety straps are recommended with all Progressive Sports Construction Group Ceiling-Suspended Folding Backstops.
- ③ If part of an installation which includes winches and backstops, place safety belt according to project drawings.
- ④ Install so safety strap does not interfere with backstop operation.
- ⑤ Progressive provides clamps to attach safety strap to Backstops; other brands require tie-off directly to the backstop.
- ⑥ Install so the strap pulls out straight and flat toward the backstop. Strap must move freely through the range of backstop motion and must not rub against anything as backstop moves; abrasion may cause strap failure.
- ⑦ Warning Tear Tab sewn in strap is designed to tear away if the unit is tripped. **Loop should not be used as an anchor point!**
- ⑧ Read all instructions prior to installation and use.
- ⑨ This unit is not a person fall protection device.
- ⑩ This unit must be replaced after catching a falling load.
- ⑪ Ensure all people are clear of backstop when operating hoisting equipment.
- ⑫ This unit is intended for indoor use only.
- ⑬ Use appropriate lock-out and tag-out procedure for backstop hoist when installing Aut-O-Loc 2™.
- ⑭ During installation, use a tether on the Aut-O-Loc 2™ that will prevent the Aut-O-Loc 2™ from falling. Ensure that people are well clear of work area, and that no-one is underneath work platform. When installing unit ensure that work platform is stable and clear of moving equipment during hoist operation. Work platform (i.e. man lifts) may tip when extended to great heights. Make sure the work platform is clear of the backstop when testing the movement of the backstop and Aut-O-Loc 2™. Do not stand on work platform during movement of backstop.

These instructions are meant as a guide only. They do not imply any responsibility on the part of Progressive Sports Construction Group for improper installation or faulty workmanship at the job site.

List of contents in the box:

Description	Quantity
Aut-O-Loc 2™	1 each
Instruction Set	1 each
Hardware packet containing:	1 each
Nut, Hex 3/8" Flange Lock	1 each
Nut, Hex, 1/2" Flange Lock	2 each
Nut, Hex 5/8" Flange Lock	1 each
Bolt, 3/8" x 3"	1 each
Bolt, 1/2" x 3"	1 each
Bolt, 1/2" x 4"	1 each
Bolt, 5/8" x 4 1/4"	1 each
Clamp, Strap, Buckle	1 each
Clamp, Pipe (for belt buckle)	1 each

Following is a list of necessary tools:

- 3/4" six or twelve point socket
- 3/4" combination open/box end wrench
- 9/16" socket & wrench (open or adjustable)
- 15/16" socket & wrench (open or adjustable)
- 5-100 ft lb torque wrench

Installation

- ① The basketball backstop must be in its deployed (down) position for installation of the Aut-O-Loc 2™.

- ② Locate the Aut-O-Loc 2™ just above and as close to the pick up point on the backstop mast as possible. The warning tear tab should be just below the white roller guides at the bottom of the Aut-O-Loc 2™ when the backstop is in the fully raised position.

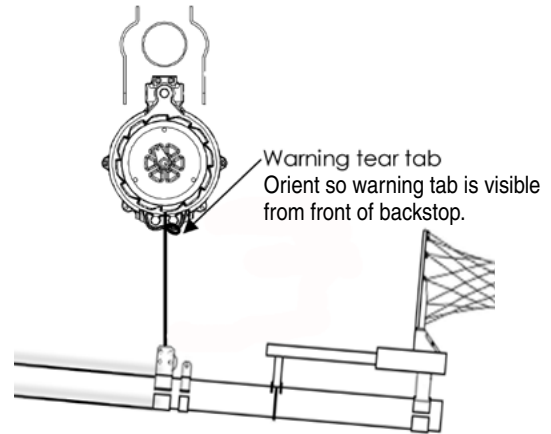

Figure 1

- ③ The Aut-O-Loc 2™ must be mounted in the center plane of backstop motion and the belt should not angle to the side or rub against any surface. Maximum belt side angle should not be greater than 1° at maximum belt payout.

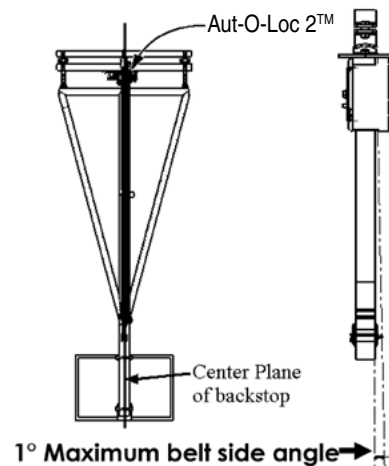

Figure 2

- ④ The Aut-O-Loc 2™ strap should be clear of obstructions throughout its sweep. These angles are installation dependant.

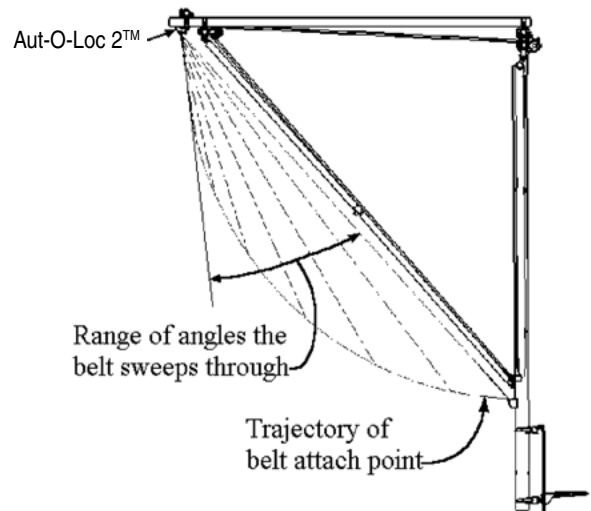

Figure 3

(Continued on page 2)

If you encounter any difficulties installing or servicing your Aut-O-Loc 2™ Safety Strap, call your dealer or Progressive Sports Construction Group, Spiceland, Ind., (765) 987-7999, or fax (765) 987-7142.

PROGRESSIVE
SPORTS CONSTRUCTION GROUP

765-987-7999
866-637-5611
411 S. Pearl St.

Spiceland IN 47385 USA
www.progressivescgroup.com

- ⑤ Insert 1/2" x 3" bolt in top clamp hole and finger tighten into opposite half clamp using 1/2" lock washer and nut. Place clamp over mounting pipe. Lift Aut-O-Loc 2™ unit up to clamp, insert 5/8" x 4 1/4" bolt through bottom hole in both clamp halves and Aut-O-Loc 2™ unit and finger tighten using 5/8" lock washer and nut. If attaching to 3 1/2" OD tube, insert 1/2" x 4" bolt in middle clamp hole and finger tighten using nut and lock washer. Position the Aut-O-Loc 2™ and hand tighten all bolts so that the Aut-O-Loc 2™ will remain in position on the pipe.

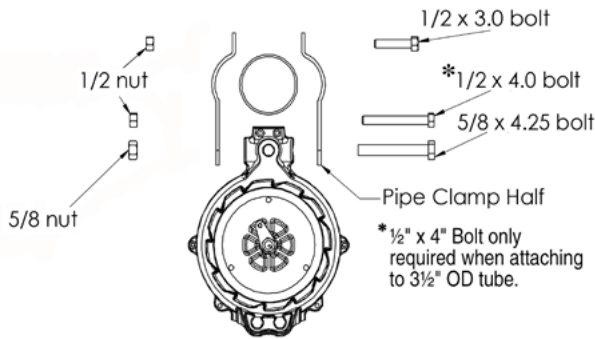

Figure 4

- ⑥ Stretch belt out and attach to mast. Use following steps to properly install belt clamp.

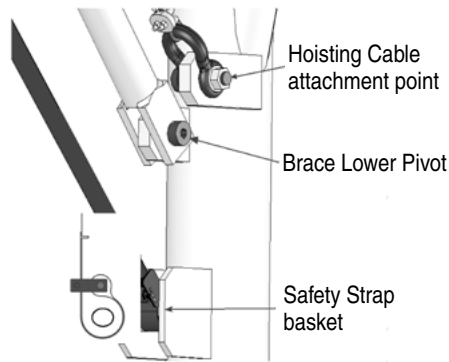

Figure 5

- ⑦ Wrap end around mast attach point. Place sewn tail of belt loop on the outside of the loop. Insert bolt through the clamp and clamp tube and tighten Nyloc nut on opposite side.

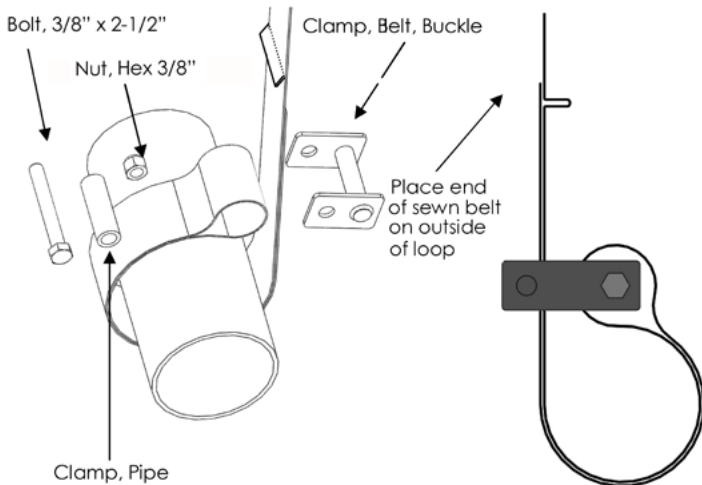

Figure 6

- ⑧ Tighten the top and middle 1/2" clamp nuts to a torque of 35 ft lbs.
 ⑨ Tighten the bottom 5/8" clamp nut to a torque of 45 ft lbs.

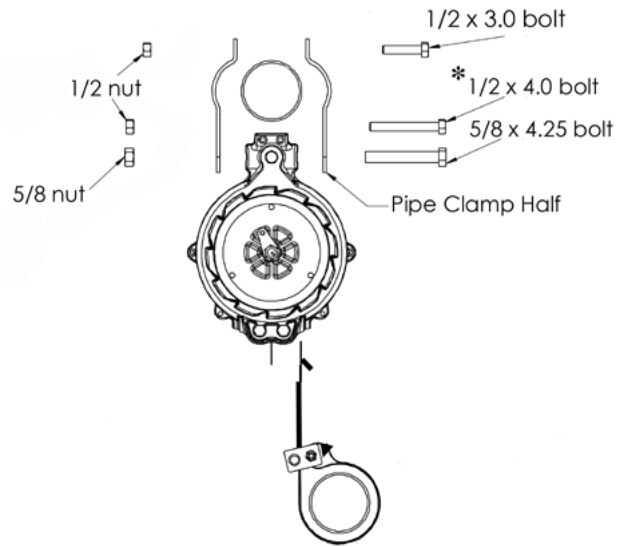

Figure 7

* 1/2" x 4" bolt only required when attaching to 3 1/2" OD tube.

- ⑩ Tighten the 5/8" bolt so the pipe clamp is tight against the surface of the cast housing and the lock washer is compressed.
 ⑪ Check belt clamp assembly, tighten 3/8" nut to 22 ft lbs torque. Run back-board through a complete up and down cycle to assure unit is working properly.