

Installation Instructions

Side Lifting Practice Cage by Progressive Sports Construction Group

Caution

- ① Locate and identify all parts using the hardware list and the drawings. "As built" drawings and hardware list are packed in hardware carton. Do not discard with packing material.
 - ② Key switch is packed in winch crate, do not discard.
 - ③ Operates on 110-120v, 60 Hz current (unless noted otherwise).
 - ④ Wiring diagram can be found inside winch limit cover panel.
 - ⑤ Instructions for attaching and wiring winch are packed in winch carton.
- NOTE:** Winch has been tested at the factory and found to be operating correctly prior to shipment.

These instructions are meant as a guide only. They do not bind Draper, Inc. in any way and do not imply any responsibility of Draper, Inc. for improper installation or faulty workmanship at the jobsite.

Hardware Installation

- ① Verify overall height and width with shop drawing to determine possible discrepancies.
- ② Attach winch support angles to winch and install winch per location shown on shop drawing.
- ③ Install drive pipe support assembly angles per location shown on shop drawing.
- ④ Attach drive pipe support assemblies to angles with threaded rod. Adjust assemblies vertically to proper height (See Figs. 1 and 2).

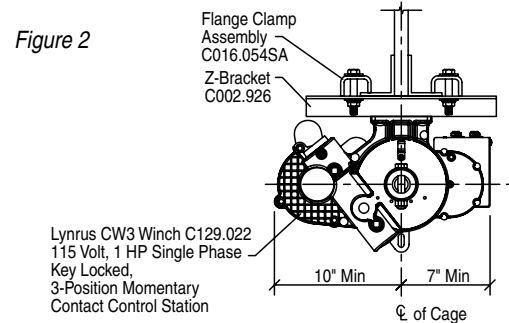
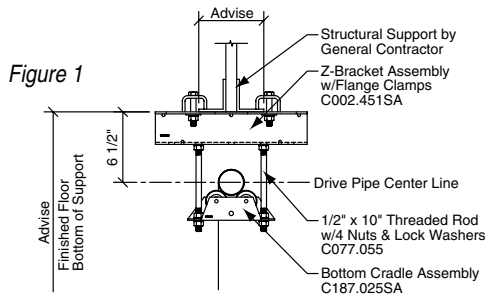

- ⑤ Raise drive pipe section that attaches to the winch. Allow to rest on motor and drive pipe support assemblies.
- ⑥ Raise other drive pipe sections. Once the drive pipe is resting in the drive pipe support assemblies, slide the proper number of cable guide sleeves onto the pipe.
- ⑦ Attach pipes together with drive pipe splicers to obtain one long continuous run of drive (See Fig. 3).

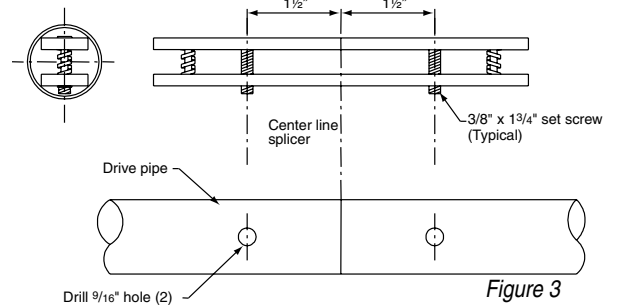

- ⑧ Attach drive tube to winch output shafts using supplied couplers, key stock and set screws (see fig 4).

ATTENTION Always insert the key stock into the slot on the motor shaft, first then slide the coupler onto the motor shaft. DO NOT INSERT KEY STOCK IN COUPLER FIRST. Tighten coupler set screw securely making sure it hits the key stock.

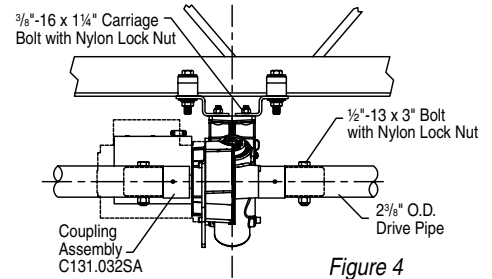

- ⑨ Operate the winch to determine that the drive pipe is rolling level. Make adjustments accordingly.
- ⑩ Slide the cable guide sleeves into their approximate location. Sleeves should be spaced approximately 2" apart at cable attachment locations.
- ⑪ Install cable guide assembly angles per location shown on shop drawings.
- ⑫ Attach the wire rope cable to the cable guide sleeves and wrap cable around the drive pipe at least three revolutions in the same direction. Drop the loose end of the drive tube side cables to the floor. Route other cables through pulleys and drop loose end to the floor.

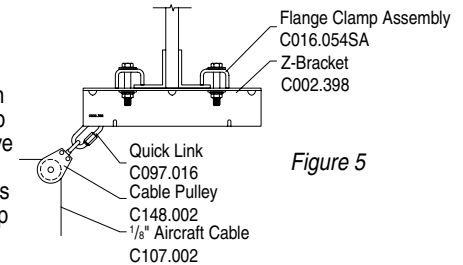

Please Note:

- The same number of pre-wraps must be maintained for all hoist lines.
- To increase the amount of line take-up on a given cable guide assembly, you must decrease the 2" dimension between the guides. To decrease the amount of take-up, increase the distance between cable guide flanges.
- Once the 3 pre-wraps are around the drive pipe, apply duct tape around cable. This will create a consistent groove for cable collection.

Frame and Net Assembly

- ① Lay out the 1 5/8" tubing, tees and elbows that make up the frame from which the net will hang, to make sure you have all the pieces.
- ② Assemble the frame.
- ③ Attach cables to frame assembly.
- ④ Test the winch operation, then set limit switches (see "Limit Switch Adjustment" section on page 2). Set "Up" limit so that frame assembly is about 6" below the drive pipe. Set the "Down" limit so the frame stops about 48" above the floor.
- ⑤ Attach net to frame using 8" hook & loop attachment strips (25 yard roll provided).

Please Note: When the Side Lifting Practice Cage is not in use, the net should be folded onto the top of the cage to minimize the storage dimension. When using the net, the cage should be lowered to allow about 12" of netting to rest on the floor. One long side of the net has two zippered corners so it may be folded on top of the frame so users can drive golf balls into the net.

Wiring diagram, limit switch adjustment instructions and dimensional drawings on page 2

Caution

Operating the cage too far in either direction could cause severe damage to the unit.

If you encounter any difficulties installing or servicing your Practice Cage, call your dealer or Progressive Sports Construction Group, (877) 413-0957 or fax (765) 987-7142.



Limit Switch Adjustment

CAUTION: Setting the limit switches is a hazardous operation. To set the limit switches you must access the hoist while the cable is installed and observe operation to determine travel direction. Lock out and tag the electrical source prior to making any actual adjustment inside the limit switch box to prevent electric shock and/or injury due to unexpected winch movement.

- Remove the limit box cover by loosening limit box cover retaining screw. Cover will slide to one side and hinge open. Cover is on a cable tether to prevent it from falling and damaging the curtain or floor.

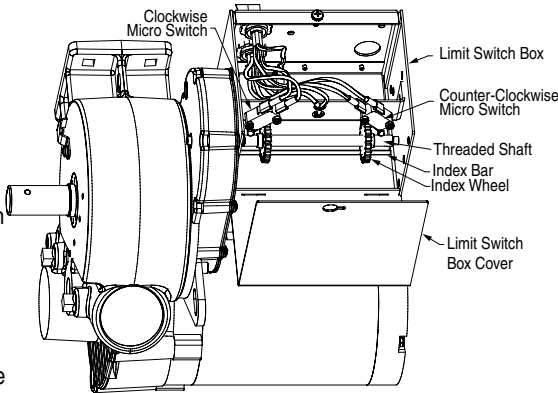
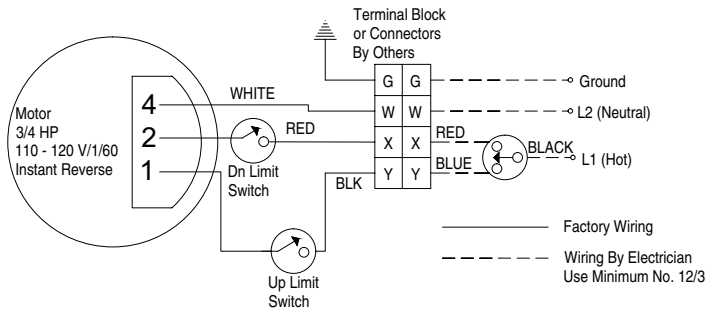

Figure 6

- Carefully observe the travel of the limit switch index wheels as the winch is operated. Two travel limit switches are provided. Which switch becomes the upper one and which becomes the lower one depends on the direction of rotation of the winch drum while the curtain is being raised. This is determined by the conditions of each installation. Carefully check which switch is for the upper travel and which is for lower travel before making any adjustments. Failure to do so could result in damage to the winch or curtain system as it may over-travel if wrong switch is adjusted.
- Operate hoist in desired direction until desired position is reached or limit switch actuates. If necessary, move index wheel to allow more travel by following steps 4 to 8 below.
- Shut off or disconnect power to winch to prevent chance of electric shock and/or injury due to unexpected winch movement.
- Push the index box toward the electrical box (away from the threaded rod) to disengage index wheel.
- Rotate index wheel toward or away from the micro switch as required.
- Release index bar ensuring that it engages index wheel.
- Turn on or reconnect power to winch and verify travel stops at desired location and repeat steps 4 to 7 as necessary for each direction of travel.
- Verify setting in each direction and reattach limit switch box cover.

Wiring Diagram



Circuit breaker rated amp.	20 amp.
Fused circuit rated amp.	20 amp.
Minimum Wire Size	
90' maximum run.....	12 ga.
90' to 140' run.....	10 ga.
Over 140'.....	8 ga.
Sizes of wall masonry boxes required for single and ganged key switches-- All boxes 2" (w) x 3 3/4" (h) x 2 1/2" (d).	

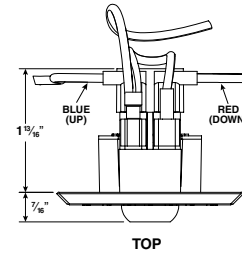
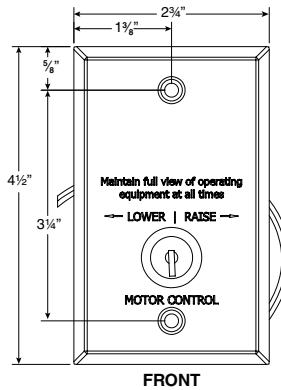

Side Lifting Practice Cage Dimensions and Details

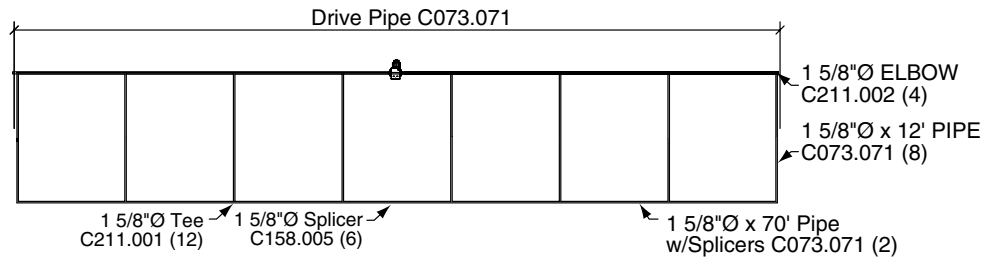

Top View

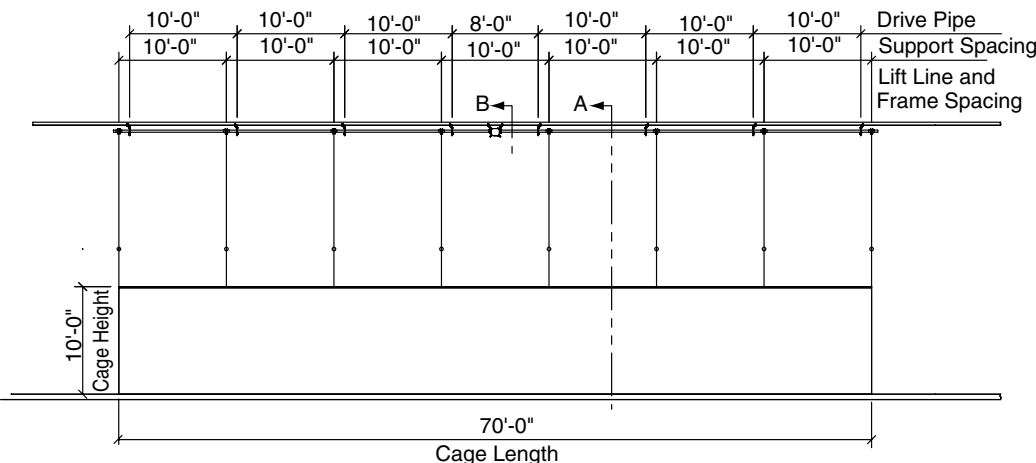
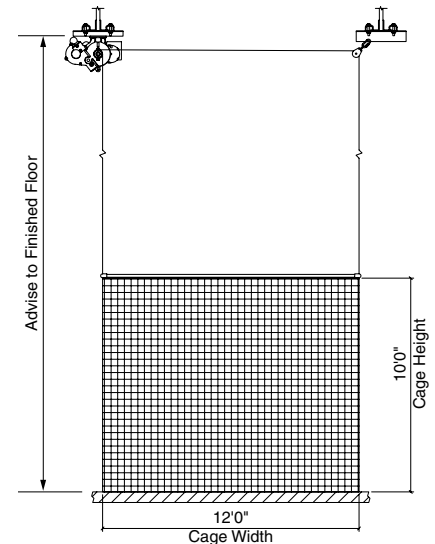

Side View

End View