

# Assembly Instructions

## Volleyball Net Winders by Progressive

### ⚠ Caution

- ① Read instructions through completely before proceeding.
- ② Before each use check equipment for proper connecting hardware and structural integrity.
- ③ Casters should be kept clean and free from debris to protect playing surface from damage.
- ④ Use of this equipment, other than intended may be hazardous and result in injury. Do not ride on cart. Injury and/or damage to cart could result.
- ⑤ Alteration or modification of this equipment may be hazardous and result in injury. For repair or replacement, contact your dealer or Progressive.
- ⑥ Unpack all parts and check against parts list to ensure that all have been included.
- ⑦ Inspect all parts for damage. Report any damages to the trucking company.

*These instructions are meant as a guide only. They do not imply any responsibility on part of Progressive for improper installation or faulty workmanship at the jobsite.*

Tools required: Socket Wrench and or Box Wrench (1), Allen Wrench (1) and Rubber Mallet (1).

### Parts List

Item	Description	Single Qty	Double Qty	Triple Qty
1	Bottom Frame	1	1	1
2	Knock Down Tower Frame	1	1	1
3	Single, Double or Triple Top Frame	1	1	1
4	Winder Frame	1	2	3
5	Handle Frame	1	2	3
6	Swivel Mount Caster	3	3	3
7	M5 - 24 mm Spring Pin	1	2	3
8	38 mm x 38 mm Cap	4	4	4
9	19 mm x 38 mm Cap	2	4	4
10	Soft Vinyl Cap-Small	3	6	9
11	Soft Vinyl Cap-Large	1	2	3
12	Soft Vinyl Cap-Medium	3	3	3
13	M6 x 1-10 mm Knurled Cap Setscrew, ZP	1	2	3
14	M8 x 1.25 Socket Pan HD Screw, ZP	1	1	1
15	M10 x 1.5 HX HD Cap Screw, ZP (Short)	2	2	2
16	M10 x 1.5 HX HD Cap Screw, ZP (Long)	2	2	2
17	M10 x 1.5 Nylon Flange Lock Nut, ZP	4	4	4
18	M14 x 1 Nylon Flange Lock Nut, ZP	4	5	6
19	M8 x 1.25 Nylon Flange Lock Nut, ZP	1	1	1
20	M10 Flat Washer, ZP	4	4	4
21	M14 Steel Washer, ZP	1	2	3
22	M14 Nylon Washer	2	4	6
23	M8 Flat Washer, ZP	1	1	1

- ① Assemble base (see Fig. 1).

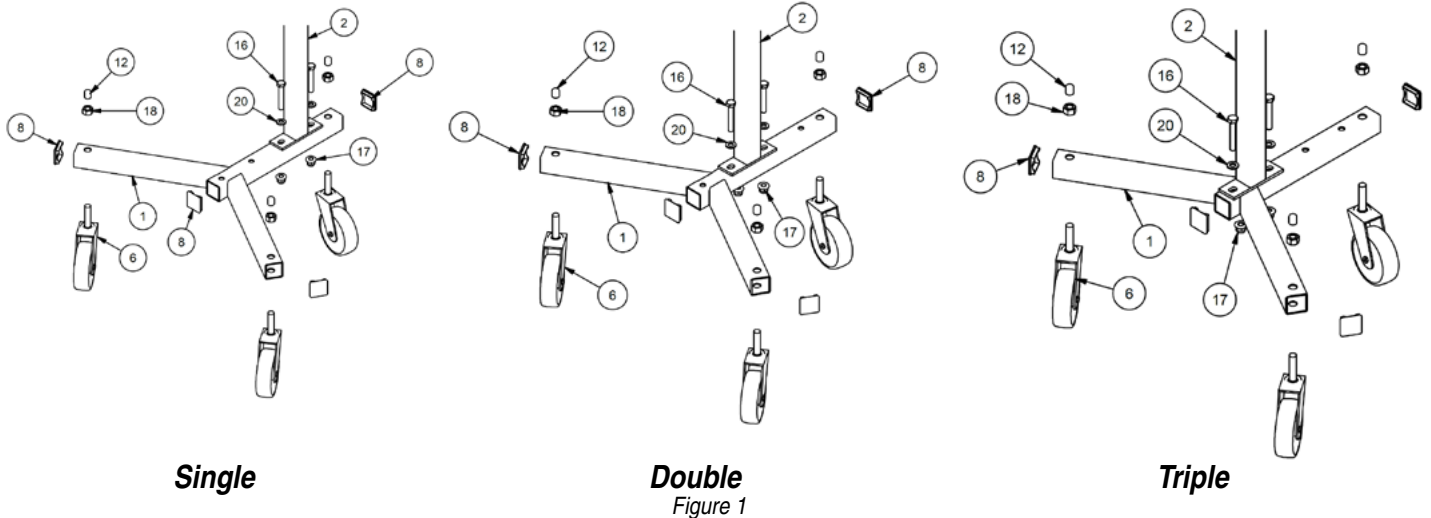

Please Note: The location of Item #2 will determine the style (see Fig. 2—Double Net Winder shown as example).

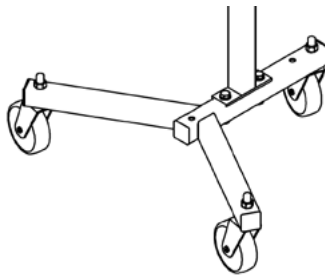

Figure 2



765-987-7999  
866-637-5611  
411 S. Pearl St.  
Spiceland IN 47385 USA  
www.progressivescg.com

Please Note: Continued on page 2.

② Assemble K-frame (see Fig. 3) and handle (see Fig. 4).

Please Note: Item # 3 will depend on how many net keepers there are. Repeat this step for each handle of the net winder.

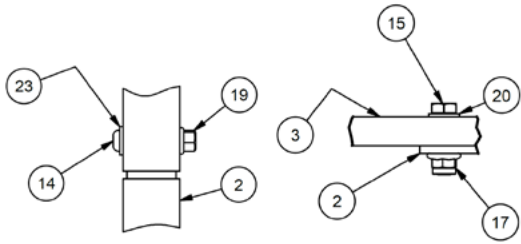

Figure 3

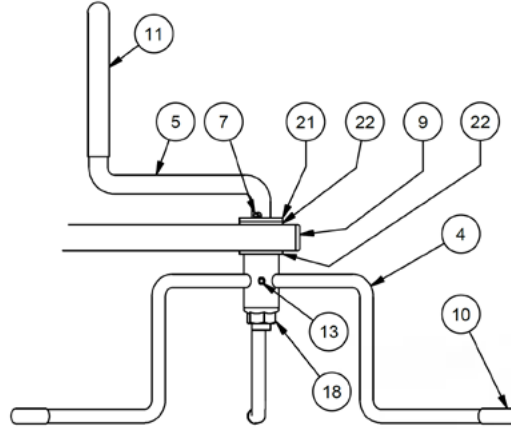
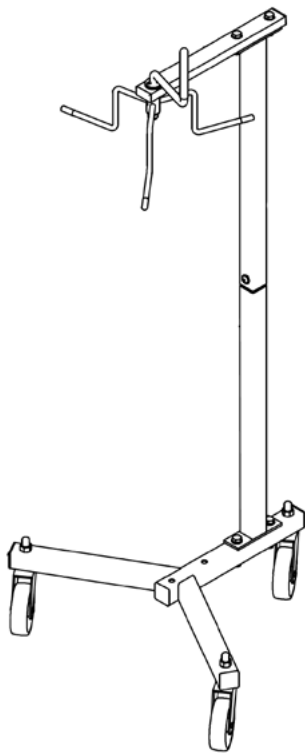
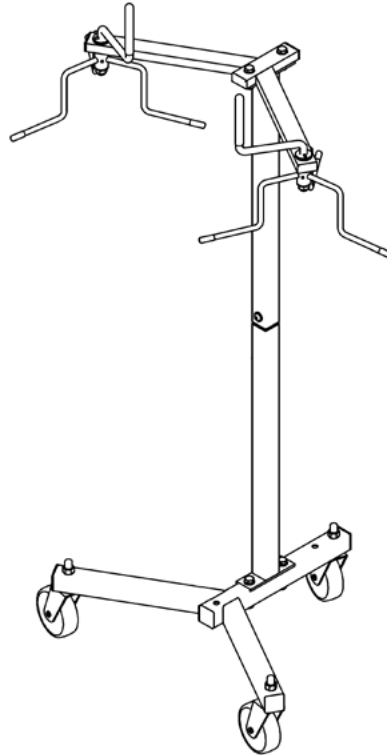

Figure 4

## Completed Product Diagrams



Single



Double

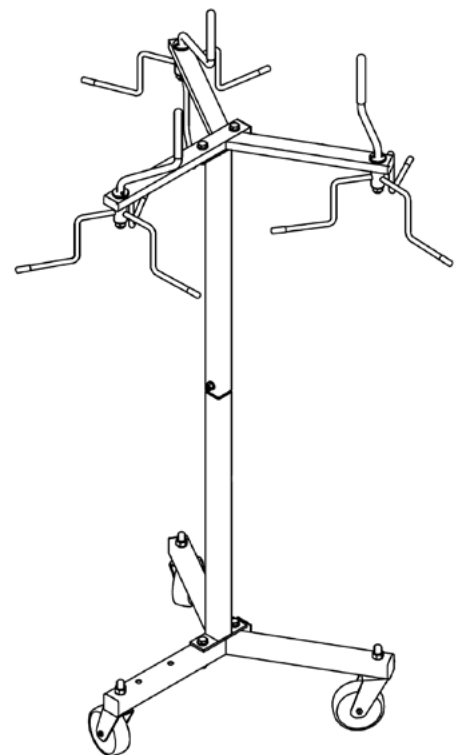

Triple