

# 502015

## Deluxe Adjustable Chinning Bar

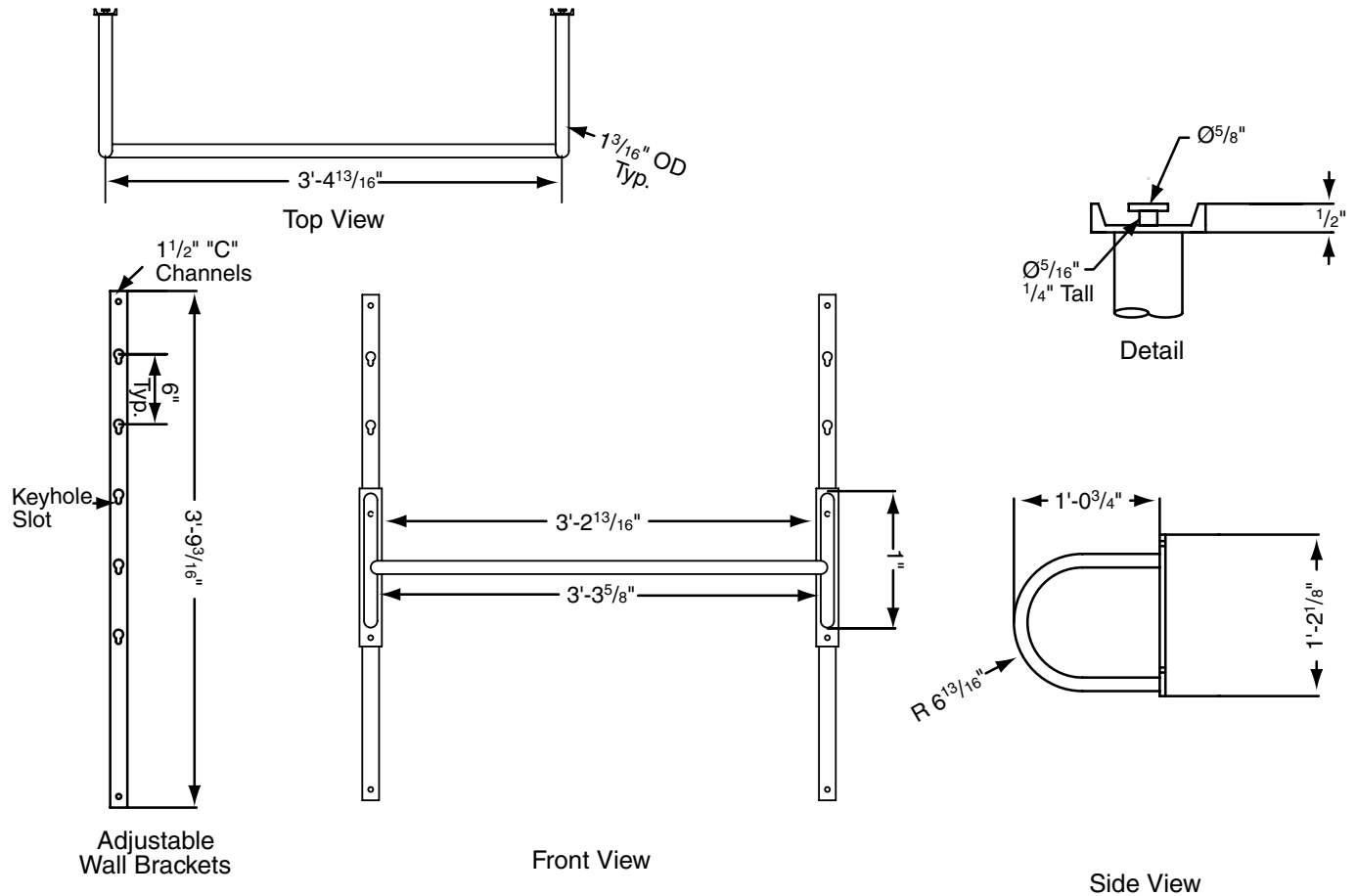

### Specifications—Deluxe Adjustable Chinning Bar

\_\_\_\_ Deluxe Adjustable Chinning Bars, #502015 by Progressive Sports Construction Group, of Spiceland, IN.

Bar assembly shall be  $1\frac{3}{16}$ " O.D. diameter steel tubing that is  $3'4\frac{3}{4}$ " long and constructed with galvanized tubing that is saddle cut and welded to two formed  $1\frac{3}{16}$ " O.D. galvanized extension frames that extend bar  $1\frac{3}{4}$ " from attachment point. Bar and formed extension frames are securely welded to 2" steel channel creating a chinning bar assembly that is designed for maximum strength and durability. Channel shall include welded steel  $\frac{1}{4}$ " tall  $\frac{5}{16}$ " dia. studs with  $\frac{5}{8}$ " dia. heads that allow for use with adjustable wall brackets. Chinning bar assembly shall be finished with durable and attractive gloss black powder coat.

Adjustable wall brackets shall be constructed with a  $1\frac{1}{2}$ " galvanized steel channel measuring  $45\frac{3}{16}$ " long. Wall brackets to include keyhole slots to accept studs on back of Chinning bar assembly. Keyhole slots to be located to allow for height adjustment in 6" increments.



765-987-7999  
866-637-5611  
411 S. Pearl St.  
Spiceland IN 47385 USA  
www.progressivescg.com

PROJECT: \_\_\_\_\_

ARCHITECT: \_\_\_\_\_

CONTRACTOR: \_\_\_\_\_

SUPPLIER: \_\_\_\_\_

DATE: \_\_\_\_\_ REVISED: \_\_\_\_\_