

# 502020 Single Mat Lifter

Mat Lifter for Single Wrestling Mat by



## Specifications—Single Mat Lifter

\_\_\_\_\_ mat lifters shall be #502020, by Progressive Sports Construction Group.

Mat Lifter construction shall consist of a welded steel frame, with all drive and lifting mechanism enclosed in a sheet metal housing. Unit shall be a two cable system to assure balanced operation. Cables shall be attached to a load bar, which shall be connected to a fabric sling. Standard unit, load bar, and sling shall be capable of supporting a standard 45' x 45' wrestling mat or sectional mats placed end to end (weighing approximately 1 lb./sq. ft.) with a 5 to 1 safety ratio.

Each unit shall consist of a 210:1 ratio double reduction worm-worm attached to an instantly reversing 2 HP motor, operating with 208/230/460 volts in 3-phase, including a 6 lb. per foot electric safety brake. Lifting and lowering speed shall be approximately 10 feet per minute.

Lifting drums shall be machine synchronized for cable wrap and driven by a 210:1 ratio gearbox. Drum shaft shall be 1 7/16" diameter cold-finished steel.

Two steel lift cables shall be 5/16" 6-strand, 37 wires per strand, fiber core. Cables shall be rated at 1704 lbs. each at a 5-to-1 safety factor.

Load bar shall be connected to a 22 oz. per square yard vinyl fabric sling with heavy duty straps and fasteners. Standard sling color is black; other colors are available by special request. Fabric sling incorporates continuous straps that wrap completely around mat to prevent mat from falling should fabric sling become torn. For safety purposes, sling capacity shall govern the lift capacity of the system.

Motors, drive assembly, and all control mechanisms shall be encased in a fireproof safety cover.

Movement control shall be by surface mounted control enclosure with limit switches.

Wiring and conduit from hoist to key switch and electrical hook-up of unit by others.

Approximate unit weight shall be 1,700 lb. (not including mat).

Structural support members and wall connections by others to meet building and unit requirements.

### For traveling mat lifter, add the following paragraph:

Mat lifter travel kit shall be driven by a .50 HP motor operating with 208/230/460 volts in 3 phase attached to a 60:1 ratio gear box with non-pneumatic wheel (s).

End first travel kit for mat lifter shall have two 1-ton machined trolleys with festooning power cables. Sideways travel models shall have four half-ton machined trolleys with festooning power cables. Motors, drive assembly, and all control mechanisms shall be encased in a fireproof safety cover.

### Wall Mounting Option:

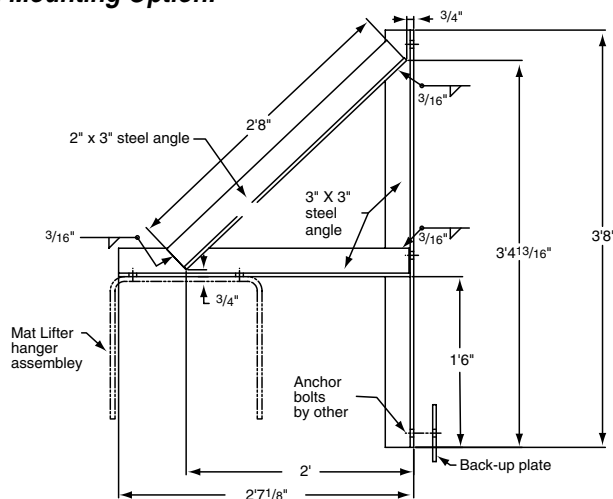

### Select Hoist Options:

- Stationary
- Traveling
  - End First Travel Kit\*
  - Sideways Travel Kit\*

**\*For Travel Kits, please provide the following information:**  
**Runway Beam (by others)**

Length: \_\_\_\_\_ Elevation: \_\_\_\_\_

- Type:  S  W  Other
- 1 (Width): \_\_\_\_\_
  - 2 (Height): \_\_\_\_\_
  - 3 (Web): \_\_\_\_\_
  - 4 (Flange): \_\_\_\_\_
  - 5 (Travel Distance): \_\_\_\_\_

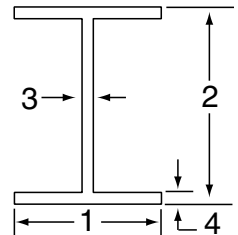

### Select Motor Options:

- 208v AC—3-Phase
- 230v AC—3-Phase
- 460v AC—3-Phase

### Mounting Options:

- Beam Mount
  - Perpendicular to structural support beams (standard)
  - Parallel to structural support beams (requires optional 502024 Beam Clamp Kit)
- Wall Mount (requires optional 502023 Wall Bracket Kit)

### Suspended Mounting Options:

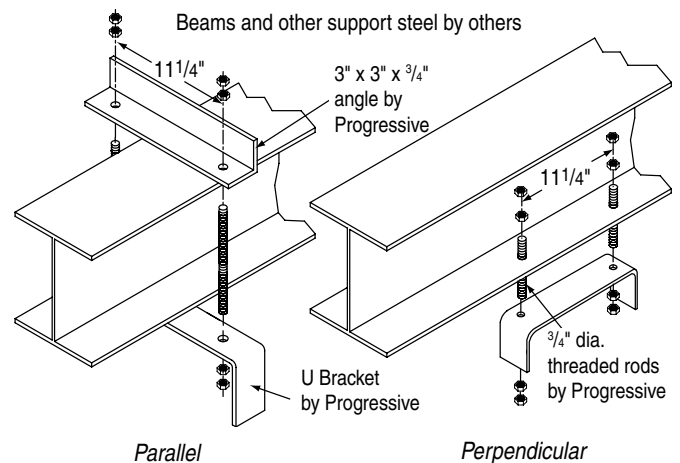

PROJECT: \_\_\_\_\_

ARCHITECT: \_\_\_\_\_

CONTRACTOR: \_\_\_\_\_

SUPPLIER: \_\_\_\_\_

DATE: \_\_\_\_\_ REVISED: \_\_\_\_\_

## 502020 Single Mat Lifter

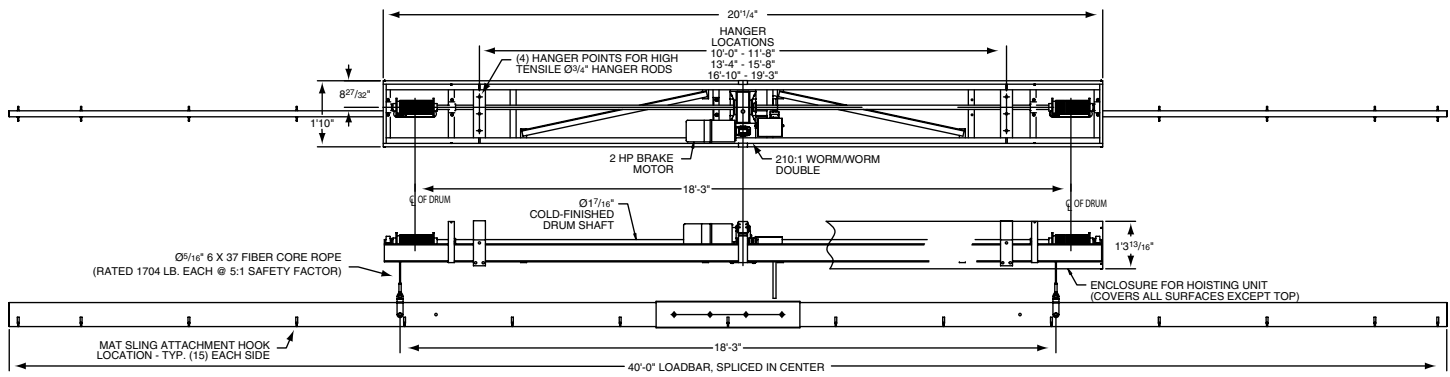

## Sideways Traveling Kit

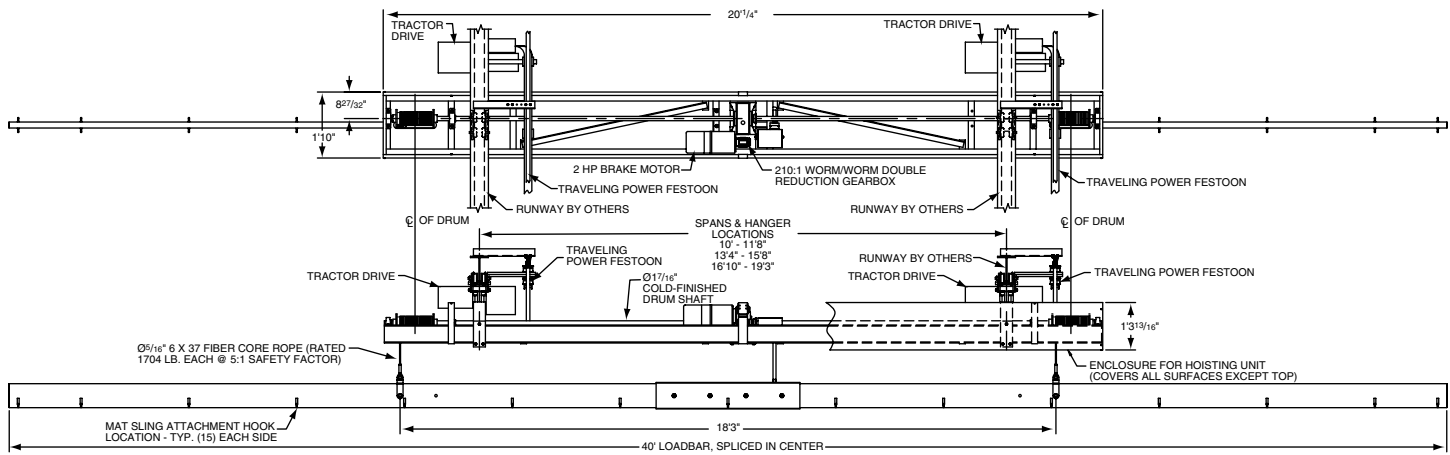

## End First Traveling Kit

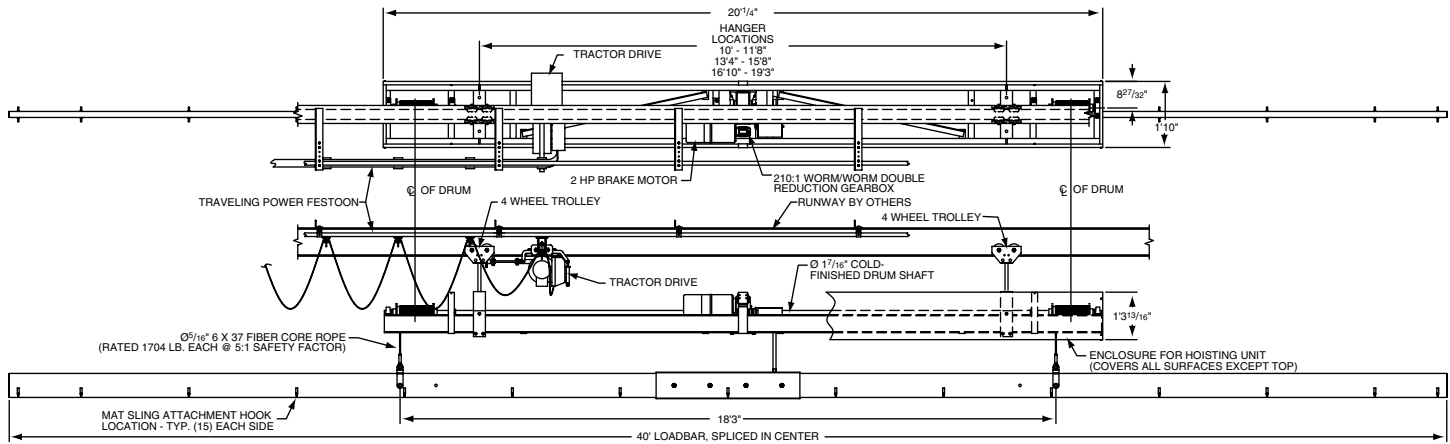

## 502020—End Views

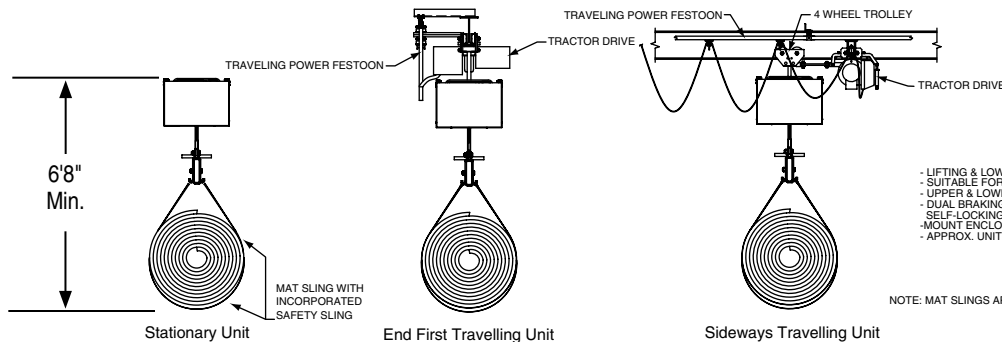

- LIFTING & LOWERING SPEED APPROX. 10 FPM
- SUITABLE FOR 45 X 45 MAT, 1.0 LB/FT
- UPPER & LOWER GEARED TRAVEL LIMIT SWITCHES
- DUAL BRAKING ACTION - MOTOR BRAKE PLUS SELF-LOCKING BEHAVIOR OF WORM GEARS - CONTROLS IN WALL
- MOUNT ENCLOSURE SHIPPED LOOSE
- APPROX. UNIT WEIGHT = 2000 LB.

NOTE: MAT SLINGS ARE DESIGNED FOR 28" DIA. MAT MAXIMUM

## Wiring Diagram—Stationary (230/460-3-60)\*

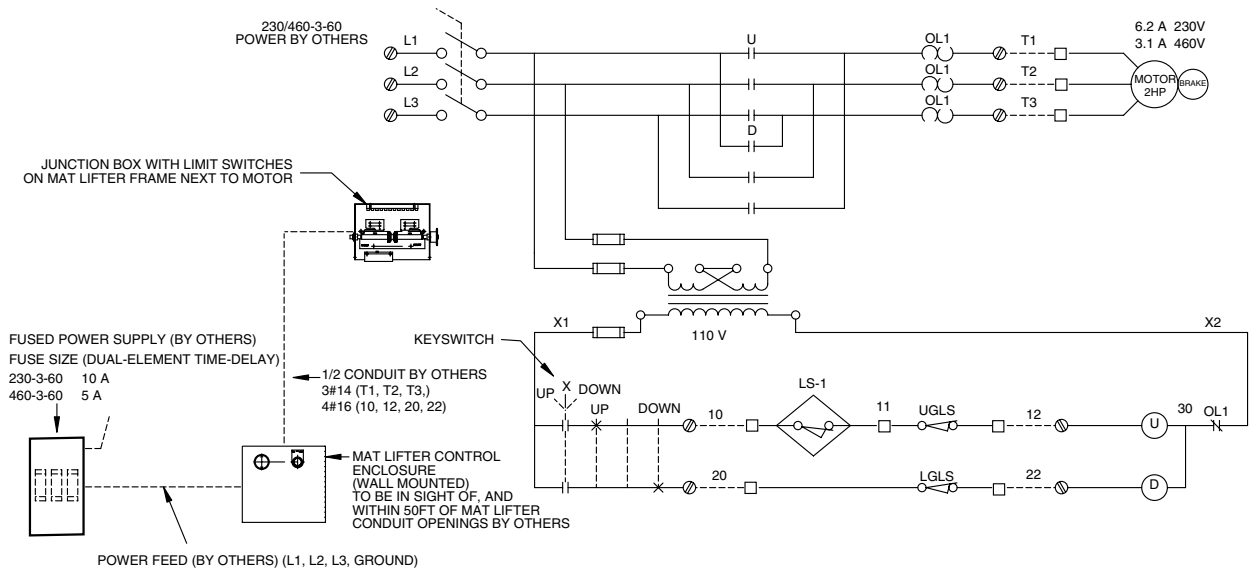

## Wiring Diagram—Stationary (208Y/120-3-60)\*

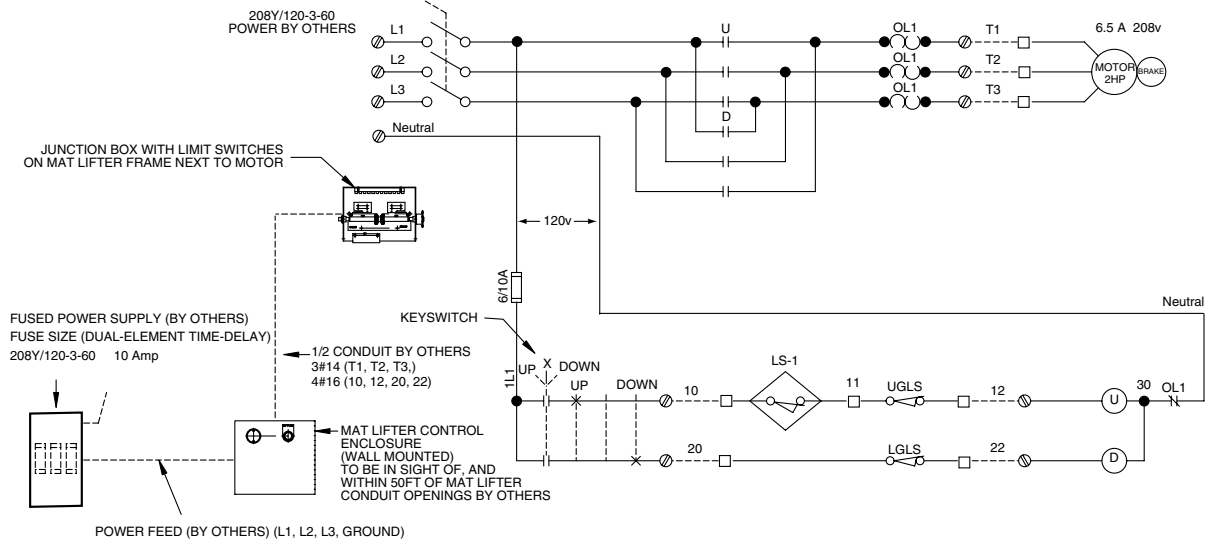

## Wiring Diagram—Traveling (230/460-3-60)\*

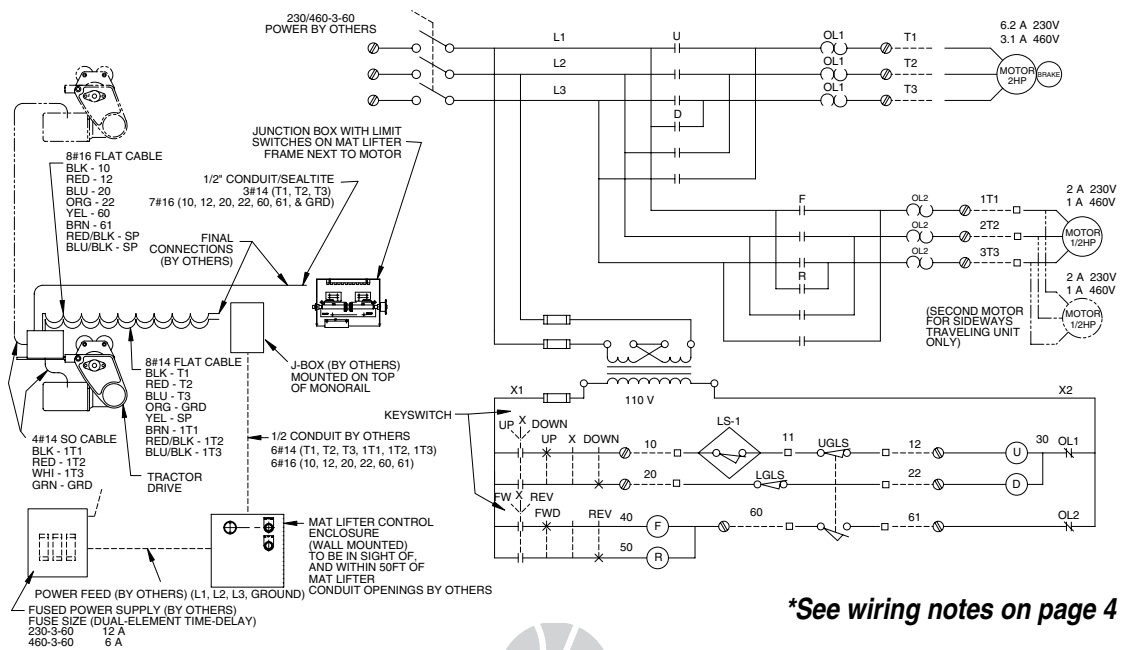

\*See wiring notes on page 4

## Wiring Diagram—Traveling (208Y-120-3-60)\*

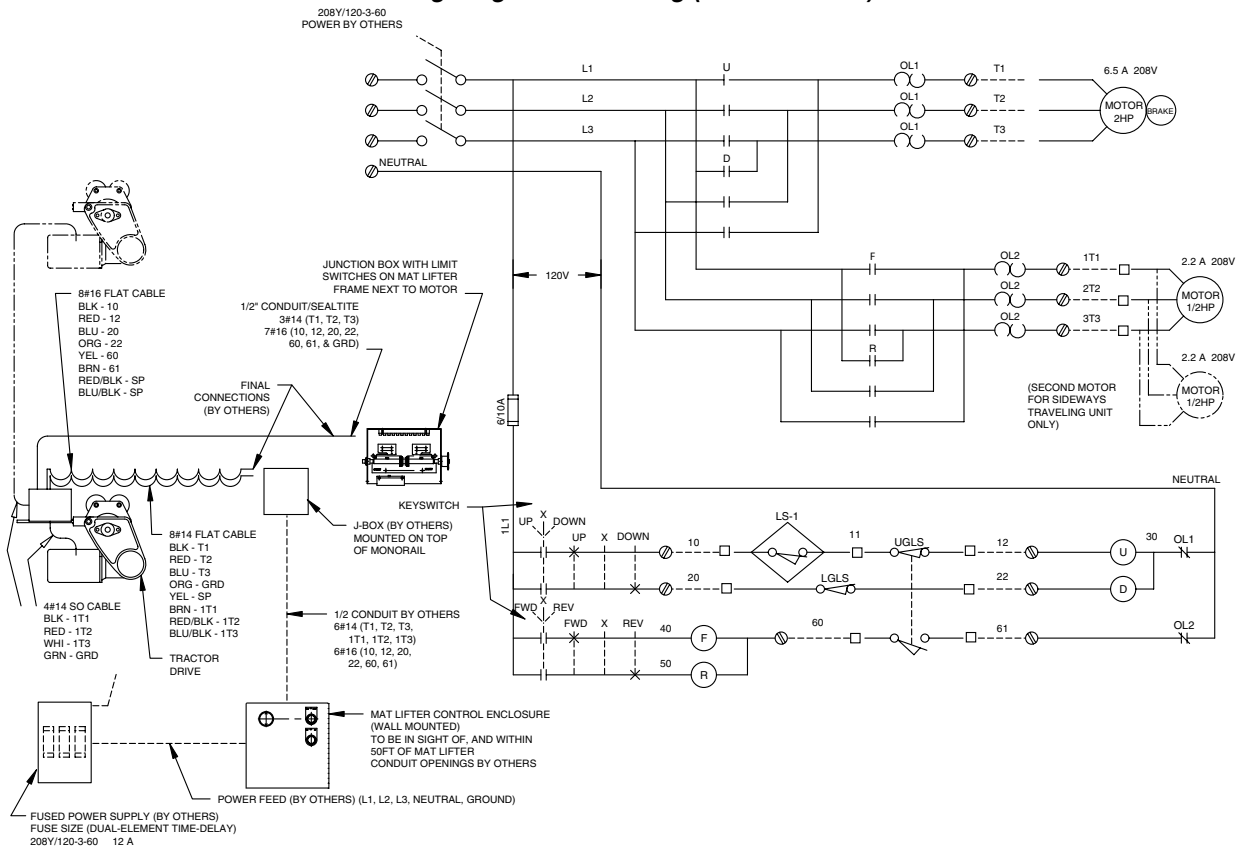

### \*Wiring Notes

**Danger:**  
Before installing, removing, inspecting, or performing any maintenance on this unit, the main switch shall be de-energized. Lock and tag the main switch in the de-energized position in accordance with ANSI Z244.1.  
This unit shall be installed and wired in accordance with ANSI/NFPA 70, National Electrical Code, and all applicable Federal, State, and Local Codes. Failure to read and comply with this and other warnings may result in serious bodily injury or death and/or property damage.

- LS-1 UPPER CONTACT PROXIMITY SWITCH 1 (EMERGENCY OVERTRAVEL)(TRIPPED IF LOADBAR IS TOO HIGH)
- UGLS UPPER GEARED LIMIT SWITCH (TRIPPED WHEN LOADBAR IS AT DESIRED UP POSITION)
- LGLS LOWER GEARED LIMIT SWITCH (TRIPPED WHEN LOADBAR IS AT DESIRED LOWER POSITION)
- FIELD WIRING PROVIDED BY OTHERS
- ⊗ TERMINALS IN CONTROLS MOUNTED TO WALL
- TERMINALS IN MAT LIFTER UNIT

### Surface Mounted Control Box

