

503079

Outdoor Breakaway Basketball
Goal with Nylon Net

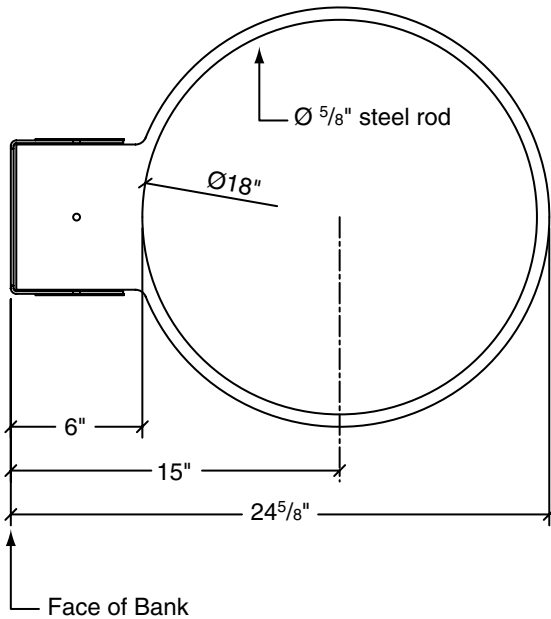

TOP VIEW

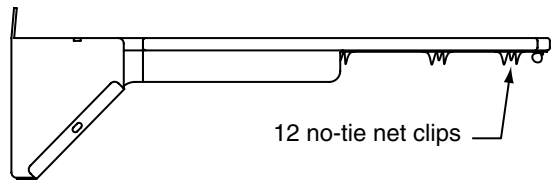

SIDE VIEW

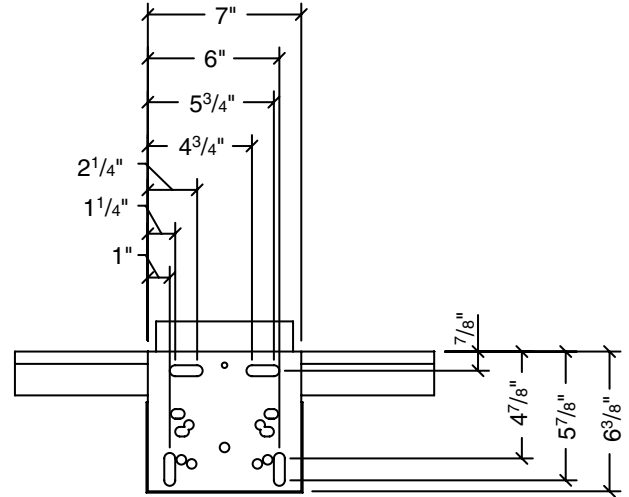

* All slots dia. 1/2" *

REAR VIEW
(Goal Mounting Plate)

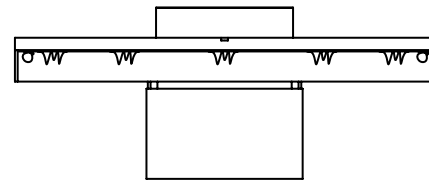

FRONT VIEW

Specifications— 503079
Outdoor Breakaway Basketball Goal with Nylon Net

Product Description

Breakaway goal is designed to withstand shock loads due to a player slam-dunking and/or hanging on the rim. Breakaway action shall be provided by a compression spring. A steel cover plate shall enclose breakaway mechanism. The rim will return to playing position once the load has been removed.

The ring shall be an official size 5/8" diameter high strength steel supported by a 3/16" x 1" support that is welded around 180° of the bottom of the ring. Inside the ring shall be positioned 6" from the face of the backboard by a 3/16" mounting plate with holes to attach to virtually any front mount backboard. Goal shall have one-piece continuous wire net attachment system. Goal shall be supplied with zinc plated mounting hardware and a heavy-duty nylon net. Goal shall have an orange powder coat finish.

Goal shall weigh approximately 27 lbs. and is covered by a one-year warranty.



PROJECT:	_____
ARCHITECT:	_____
CONTRACTOR:	_____
SUPPLIER:	_____
DATE:	_____
REVISED:	_____