

# 817-FFRB

**Ceiling Suspended Single  
Drop Mast Forward Fold, Rear  
Braced Backstop (18' to 28')**

by

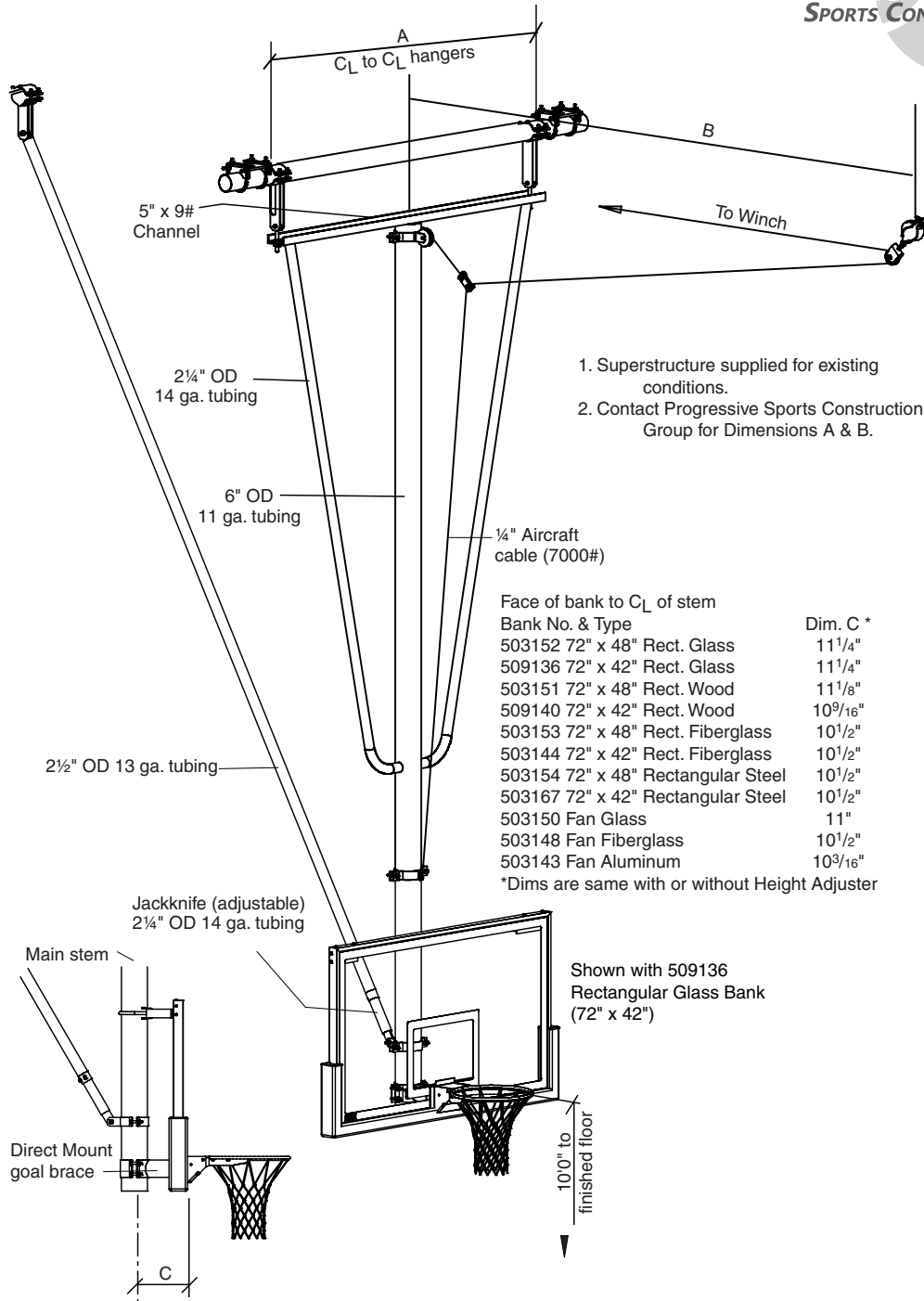

1. Superstructure supplied for existing conditions.
2. Contact Progressive Sports Construction Group for Dimensions A & B.

Face of bank to  $C_L$  of stem

Bank No. & Type	Dim. C *
503152 72" x 48" Rect. Glass	11 1/4"
509136 72" x 42" Rect. Glass	11 1/4"
503151 72" x 48" Rect. Wood	11 1/8"
509140 72" x 42" Rect. Wood	10 9/16"
503153 72" x 48" Rect. Fiberglass	10 1/2"
503144 72" x 42" Rect. Fiberglass	10 1/2"
503154 72" x 48" Rectangular Steel	10 1/2"
503167 72" x 42" Rectangular Steel	10 1/2"
503150 Fan Glass	11"
503148 Fan Fiberglass	10 1/2"
503143 Fan Aluminum	10 9/16"

\*Dims are same with or without Height Adjuster

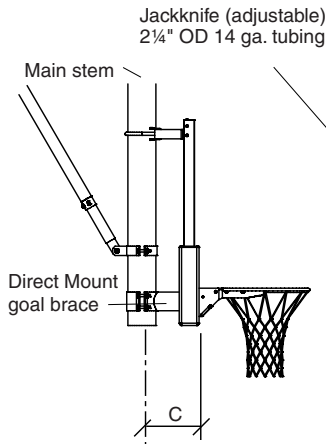

**Side View/Goal Brace Detail**

"Goal Brace" feature attaches directly behind goal mounting plate and directly to main stem of backstop, which eliminates strain on backboards.

PROJECT: \_\_\_\_\_

ARCHITECT: \_\_\_\_\_

CONTRACTOR: \_\_\_\_\_

SUPPLIER: \_\_\_\_\_

DATE: \_\_\_\_\_ REVISED: \_\_\_\_\_



765-987-7999  
866-637-5611  
411 S. Pearl St.  
Spiceland IN 47385 USA  
www.progressivescg.com

**Specifications—Progressive 817-FFRB**

*Ceiling Suspended Single Drop Mast, Forward Fold, Rear Braced Backstop (18' to 28')*

**Product Description**

**MAST:** Shall consist of a main, single mast assembled of 6" O.D., 11 gauge steel mechanical tube with diagonal side sway braces of 2¼" O.D., 14 gauge steel mechanical tube welded together at the top with a heavy 5" x 9 lbs. structural "C" channel forming a rigid double triangular structure. Sway brace shall be formed at the bottom so as to meet the main mast at such an angle as to transfer lateral forces directly into the anti-sway braces. Anti-sway braces shall intersect the mast no more than 36" above the top of the backboard. Certified welders meeting the requirements of AWS D1.1- Structural Steel Welding Code shall do all welding.

**BRACE:** Backstop shall be braced to the rear and shall fold up to the front. The brace shall be constructed of 2½" O.D., 13 gauge (outer) steel tubing and 2¼" O.D., 14 gauge (inner) steel tubing. The rear brace assembly shall be a telescopic design with an adjustable stop collar for exact positioning at installation, and maintenance free operation. The brace assembly locks the unit into playing position when down and is quickly and smoothly disengaged automatically by the simple tensioning of the cable during the act of raising the backstop into its stored position.

**SUPPORT:** Backstop shall be supported and suspended from 4" O.D., 11 gauge steel mechanical tubing anchored to roof structure by means of heavy precision formed and/or welded steel support fittings. Fittings are designed to be capable of supporting a static load of at least 10,000 lbs., without deflection. Each support system is designed with sufficient attachment points to the roof framing structure to result in a (60:1) safety factor for support on entire backstop assembly. All 4" O.D. Superstructure tubes with a span exceeding 12' shall be reinforced with special welded bridge trussing.

**GOAL:** Goal shall mount directly through the bank and into a heavy structural steel weldment, which shall be clamped to the vertical 6" O.D., main mast to eliminate any strain on the bank should a player hang on the front of the mounted goal (see latest NCAA rules). The upper bank extension assembly shall provide the official NCAA and NFHS regulation of 6" (15.24cm) minimum from the front of the main mast to the face of the backboard.

**OPERATION:** The main mast shall be suspended from at least two (2) custom adjustable hangers with bronze bushings. Offsets in the posi-

tion of the hinges designed to place center of gravity forward of hinge point insuring that the unit locks securely and automatically into the playing position. This also enables the installer to guarantee precise plumbing and height adjustment of frame during installation. The hoist cable shall be ¼" diameter galvanized aircraft cable with 7000 lbs. breaking strength. Backstop shall not be supplied with any winch. To operate, unit must utilize either the Model 503286 heavy duty worm gear type, wall mounted manual winch designed to hold backstop in any position during raising or lowering of backboard or the Model 503285 electrically operated, maintenance free instant reverse winch, specified separately. For complete specifications, see separate sheets.

**FINISH:** All metal parts shall be finished with choice of gloss black or gloss white powder coat. Other colors optionally available.

**WARRANTY:** There is a 25-year limited warranty on all Progressive backstop structures and fittings, limited lifetime warranty on all Progressive backboards when used in conjunction with the #800 Single Mast series Backstops.

**OPTIONS:** Backstop can be provided with any of several different styles of backboards, goals and padding. Specify types desired.

**ACCESSORIES:** See separate sheets for Height Adjuster, Safety Strap, and Control Systems.

**LEED® Submittal Information**

Credit	Measure	
MRc4 – Recycled Content	Post Consumer Average 51.21%	Post Industrial 0%
MRc5 – Regional Materials	Raw materials are commodity items from multiple sources so extraction point cannot be determined. Final Manufacturing/Assembly in Spiceland, IN 47385	

**Hanger Detail**

