

818-WB

Ceiling Suspended Single Drop Mast, Stationary Wall Braced Backstop (18'-28')

by

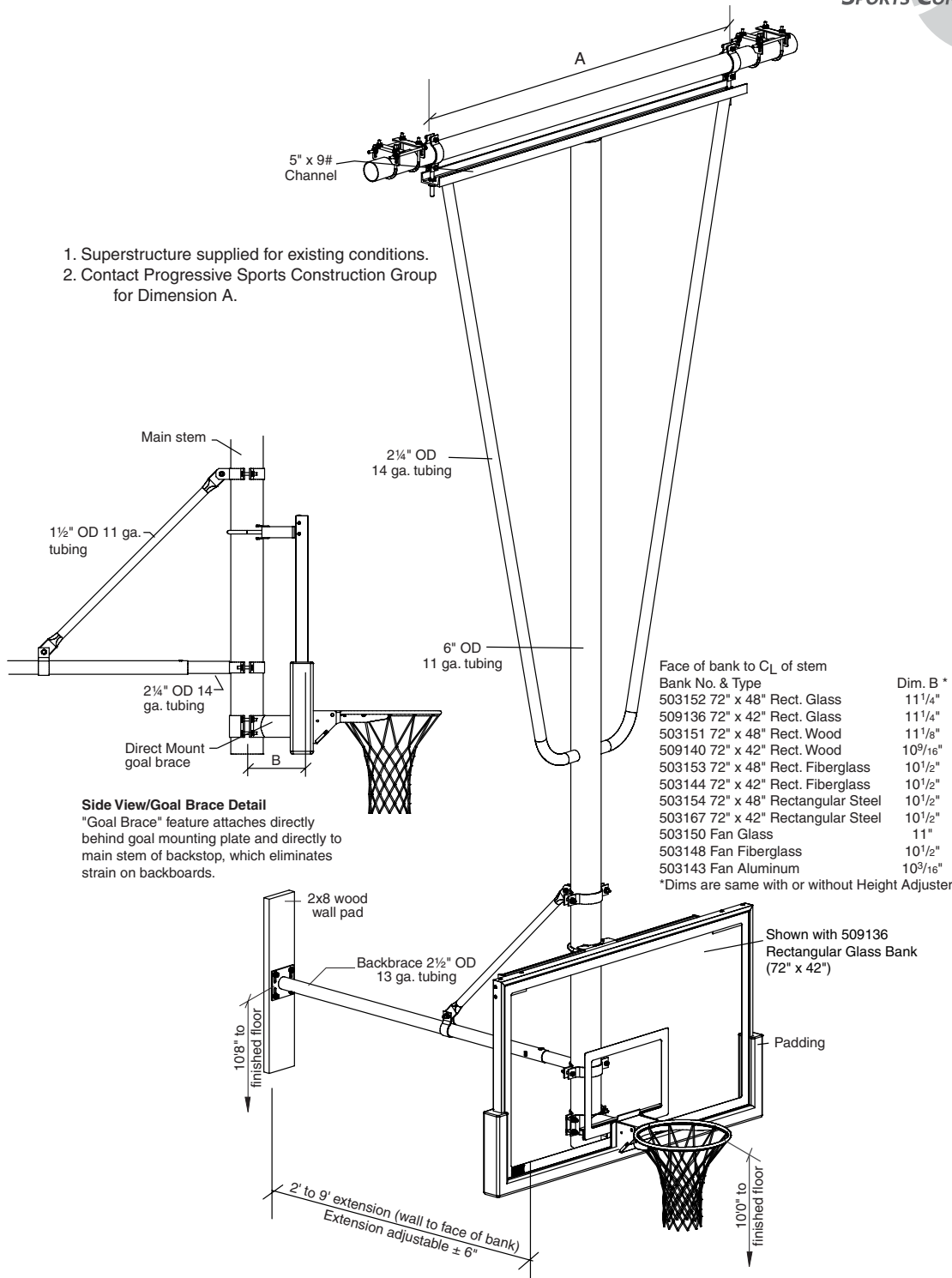

765-987-7999
866-637-5611
411 S. Pearl St.
Spiceland IN 47385 USA
www.progressivescg.com

PROJECT: _____

ARCHITECT: _____

CONTRACTOR: _____

SUPPLIER: _____

DATE: _____ REVISED: _____

Specifications—Progressive 818-WB

Ceiling Suspended Single Drop Mast, Stationary, Wall Braced Backstop (18'-28')

Product Description

MAST: Shall consist of a main, single mast assembled of 6" O.D., 11 gauge steel mechanical tube with diagonal side sway braces of 2¼" O.D., 14 gauge steel mechanical tube welded together at the top with a heavy 5" x 9 Lbs. structural "C" channel forming a rigid double triangular structure. Bottom of sway brace shall be formed at the bottom so as to meet the main mast at such an angle as to transfer lateral forces directly into the braces. Braces shall intersect the mast no more than 36" above the top of the backboard. Certified welders meeting the requirements of AWS D1.1- Structural Steel Welding Code shall do all welding.

BRACE: Backstop shall be braced to the rear anchoring at the wall. The brace shall be adjustable and constructed of 2½" OD 13 gauge (outer) and 2¼" 14 gauge (inner) steel tubing. The brace assembly terminates at the wall thru the use of special fittings and Southern Yellow Pine wall stringer. Anchors to the wall will be specified by the Architect and provided by the installer to meet wall requirements and local code requirements and exact building conditions.

SUPPORT: Backstop shall be supported and suspended from 4" O.D., 11 gage steel mechanical tubing anchored to roof structure by means of heavy precision formed and/or welded steel support fittings. Fittings are designed to be capable of supporting a static load of at least 10,000 lbs., without deflection. Each support system is designed with sufficient attachment points to the roof framing structure to result in a (60:1) safety factor for support on entire backstop assembly. All 4" O.D. Superstructure tubes with a span exceeding 12' shall be reinforced with special welded bridge trussing.

GOAL: Goal shall mount directly through the bank and into a heavy structural steel weldment, which shall be clamped to the vertical 6" O.D., main mast to eliminate any strain on the bank should a player hang on the front of the mounted goal (see latest NCAA rules). The upper bank extension assembly shall provide the official NCAA and

NFHS regulation of 6" (15.24cm) minimum from the front of the main mast to the face of the backboard.

OPERATION: The main mast shall be suspended from two (2) custom adjustable hangers enabling the installer to guarantee precise plumbing and height adjustment of frame during installation.

FINISH: All metal parts shall be finished with choice of gloss black or gloss white powder coat. Other colors optionally available.

WARRANTY: There is a 25-year limited warranty on all Progressive backstop structures and fittings, limited lifetime warranty on all Progressive backboards when used in conjunction with the #800 Single Mast series Backstops.

OPTIONS: Backstop can be provided with any of several different styles of backboards, goals and padding. Specify types desired.

ACCESSORIES: See separate sheets for Height Adjuster, Safety Strap, and Control Systems.

LEED® Submittal Information

Credit	Measure	
MRc4 – Recycled Content	Post Consumer Average 51.21%	Post Industrial 0%
MRc5 – Regional Materials	Raw materials are commodity items from multiple sources so extraction point cannot be determined. Final Manufacturing/Assembly in Spiceland, IN 47385	