

Fold-Up Divider

Section Drawing

Shown directly under continuous beam

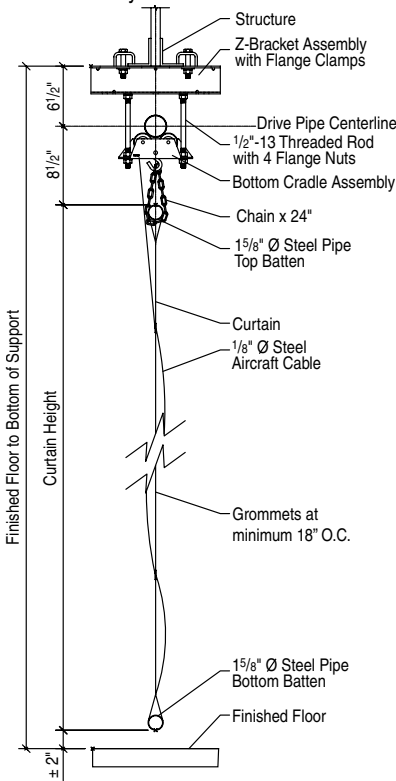

Electrically Operated
Gym Divider Curtain



Specifications—Fold-Up Gym Divider

Gym Divider as shown on plans shall be Fold-Up as manufactured by Progressive Sports Construction Group. Bidder is responsible for verification of job conditions and dimensions.

Lower section of curtain shall be solid vinyl coated polyester (avg. 18 oz. or 22 oz. per square yard as required). Flammability rated as self extinguishing by the California State Fire Code and Class A Rated in accordance with requirements of NFPA-101. All seams to be electronically welded with a 1" full contact weld. Outer edge hems shall be triple turned with double welds. A pocket shall be formed along the bottom edge of the curtain to accommodate a 1 5/8" diameter round batten for curtain support.

Upper section of curtain shall be avg. 9 oz. per square yard vinyl coated polyester mesh. Flammability rated as self extinguishing by the California State Fire Code and Class A Rated in accordance with requirements of NFPA-101. Color shall be chosen from standard offering as specified by the owner. Use vinyl fabric, in triple thickness and double welded to the top edge of the mesh, to form a 6" wide pocket to accommodate a 1 5/8" diameter round batten for curtain support.

18 oz. Divider Curtain Vinyl and Divider Curtain Mesh has achieved GREENGUARD GOLD Certification. GREENGUARD Certified products are certified to GREENGUARD standards for low chemical emissions into indoor air during product usage. For more information, visit ul.com/gg.

Suspension from roof support member must be accomplished with clamp type malleable or heavy gauge stamped lug fitting furnished by the manufacturer. Hoist lines shall be 1/8" diameter steel aircraft cable (2000 lb. break strength), spaced maximum 10'0" on center. Each line shall be attached to the bottom tube batten and run through grommets located approximately 18" on center for attachment heights 30' and below, 24" for attachment heights between 30' 1" and 40' and 30" for attachment heights above 40'. Each hoisting line shall terminate at the top of the curtain and attach to a drive pipe. The drive pipe shall rotate in drive pipe support assembly located a maximum of 10'-0" on center. Hoisting mechanism shall not rely on single cable support of the divider when in stored position.

Drive pipe power mechanism shall consist of a 3/4 H.P., 110-120 volt, 60 cycle, single phase reversible capacitor motor with built-in thermal overload protection. The motor and load holding worm gear reducer shall provide speed reduction in the winch. Remote control operation to include integral limit switch to control the upper and lower limit of the curtain travel. Key lock, three position, momentary contact wall switch with safety delay included. Switch unit shall include a general purpose switch box wall plate. Key switch or controls to be in full view of both sides of curtain during operation.

Optional Group Control System. See separate sheet for details.

Optional Wireless Remote Control. See separate sheet for details.

LEED® Submittal Information

Credit	Measure	
MRC4 – Recycled Content	Post Consumer Average 23.48%	Post Industrial 0%
MRC5 – Regional Materials	Raw materials are commodity items with multiple sources so extraction point cannot be determined. Final manufacturing/assembly in Spiceland, IN 47385	

Considerations for Fold-Up Divider

- Divider can be made virtually any size, but cannot be cutout for bleachers. Allow more space for walking around the ends of the divider. A minimum of 6 inches of clearance is required between vertical edges and fixed objects.
- Stored dimension, from the bottom of beam to the bottom of the divider, shall be three feet or less with a level direct attachment.

PROJECT: _____
ARCHITECT: _____
CONTRACTOR: _____
SUPPLIER: _____
DATE: _____ REVISED: _____

Please Mark Appropriate Selections Select Solid Vinyl Weight and Color

Specify Height of Vinyl: _____

- 18 oz. (circle one)
- | | | | | |
|--------|-------------|--------------|-----------|--------|
| White | Marine Blue | Forest Green | Yellow | Orange |
| Purple | Black | Red | Dark Blue | Maroon |
| Beige | Grey | Navy | | |

- 22 oz. (circle one)
- | | | | | |
|-----|-----------|------|--|--|
| Red | Dark Blue | Grey | | |
|-----|-----------|------|--|--|

Select Mesh Color (circle one)

- | | | | |
|-------|------|------|--------|
| White | Red | Blue | Yellow |
| Black | Grey | | |

Specify Width

Opening Width: _____

Divider Curtain Width: _____

Specify Height

Height (floor to attachment): Low Point: _____ High Point: _____

Obstructions (clarify on page two in NOTES): _____

Building Structure in Relation to Curtain

- Directly under continuous beam
- Between two beams. Distance between beams: _____
Distance between beam and curtain: _____
- Right Angle to beams. Spacing between beams: _____

Building Structure for Curtain Support

Beam flange width: _____

Beam flange thickness: _____

Options for Fold-Up Divider

- Padded bottom batten
- Wireless remote control (see separate submittal sheet)
- Group Control System (see separate submittal sheets)



765-987-7999
866-637-5611
411 S. Pearl St.
Spiceland IN 47385 USA
www.progressivescgroup.com

Height and width

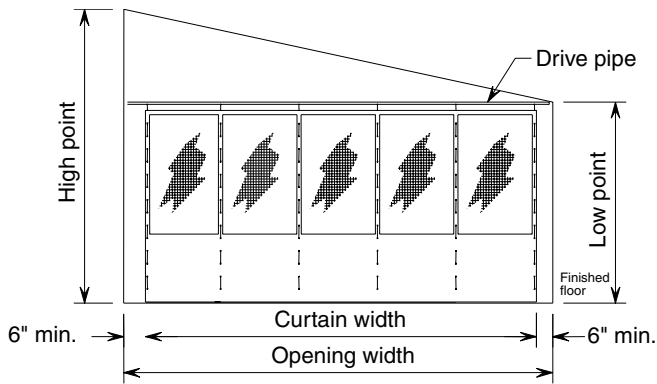
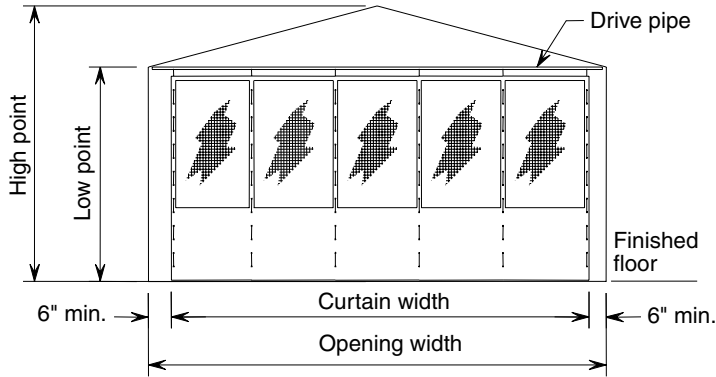

Structural relations

Between two beams

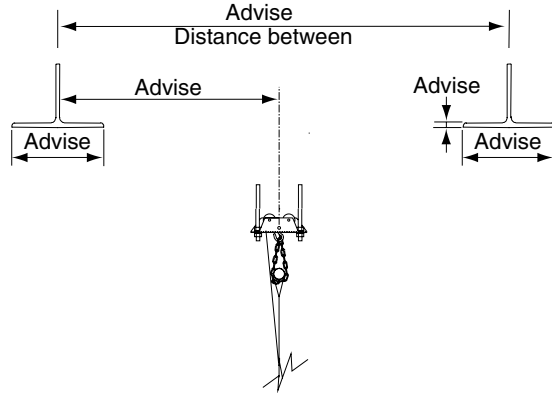

Right angle to beams

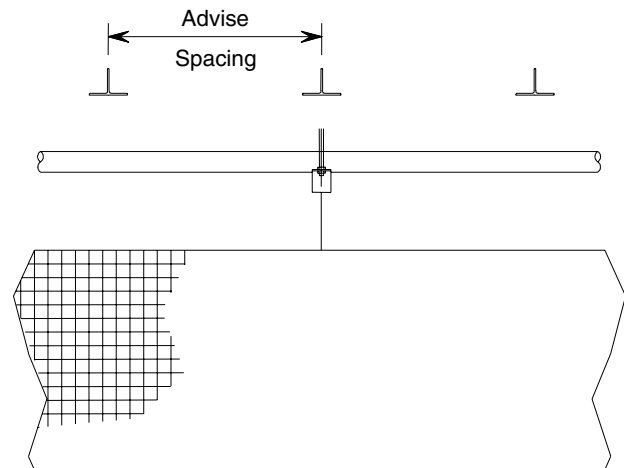

Notes:

Wiring Diagram

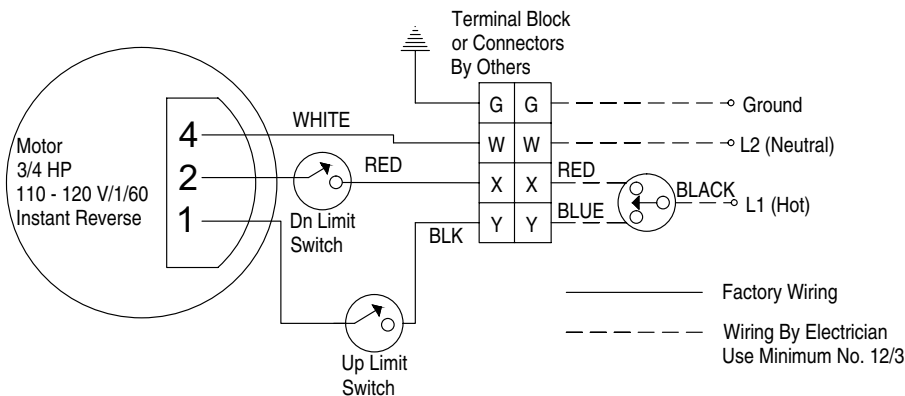

Key Switch

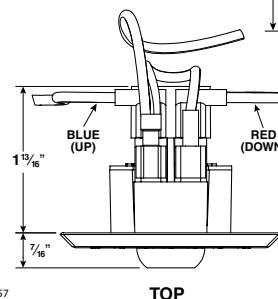
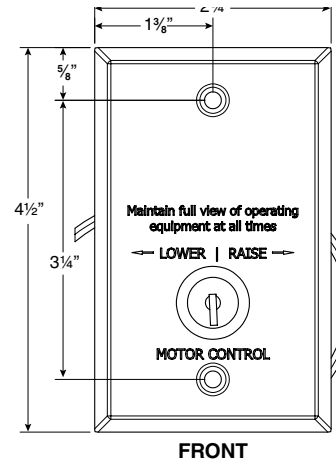

Circuit breaker rated amp. 20 amp. Fused circuit rated amp. 20 amp.
Minimum Wire Size
90' maximum run. 12 ga.
90' to 140' run. 10 ga.
Over 140'. 8 ga.
Sizes of wall masonry boxes required for single and ganged key switches-- All boxes 2" (w) x 3 3/4" (h) x 2 1/2" (d).