

Volleyball Floor Cover Plates

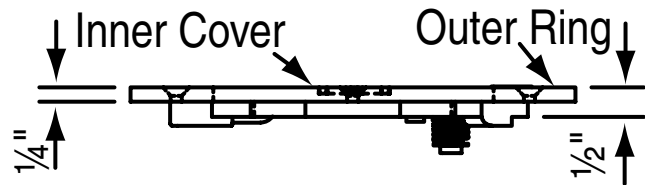

501035

Locking Brass Floor Cover Plate

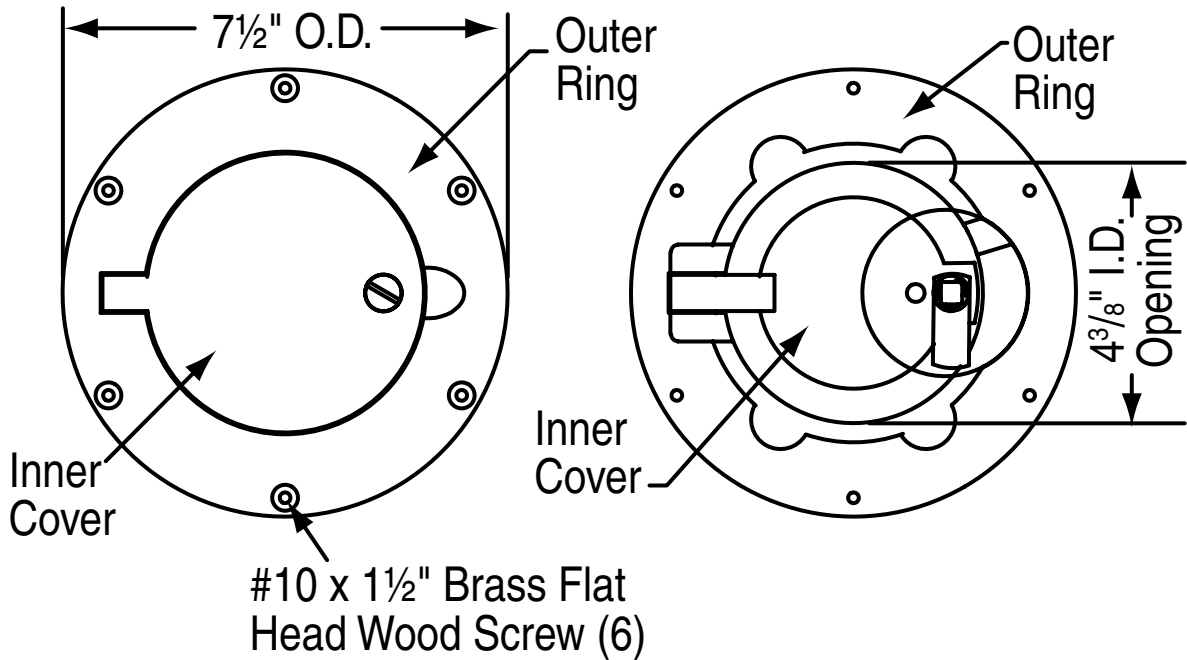

Specifications—501035

Locking Brass Floor Cover Plate Assembly

Locking Brass Cover Plate Assembly shall be 501035 by Progressive Sports Construction Group. Cover plate assembly shall be solid brass alloy with permanently attached hinged cover. Cover plate assembly shall be 7 1/2" outside diameter by 1/2" thick. The diameter of opening shall be 4 3/8". Cover plate assembly features a lock mechanism that secures cover to ring preventing it from bouncing or creating a dead spot if hit with a ball.

Outer ring shall have six mounting holes to allow cover plate to be securely attached to floor. Floor plate is supplied with six #10 x 1 1/2" brass flat head wood screws for mounting plate to floor. Plate shall be installed flush with playing surface.

LEED® Submittal Information

Credit	Measure	
MRc4 – Recycled Content	Post Consumer Average 58%	Post Industrial 0%



PROJECT: _____
ARCHITECT: _____
CONTRACTOR: _____
SUPPLIER: _____
DATE: _____ REVISED: _____